

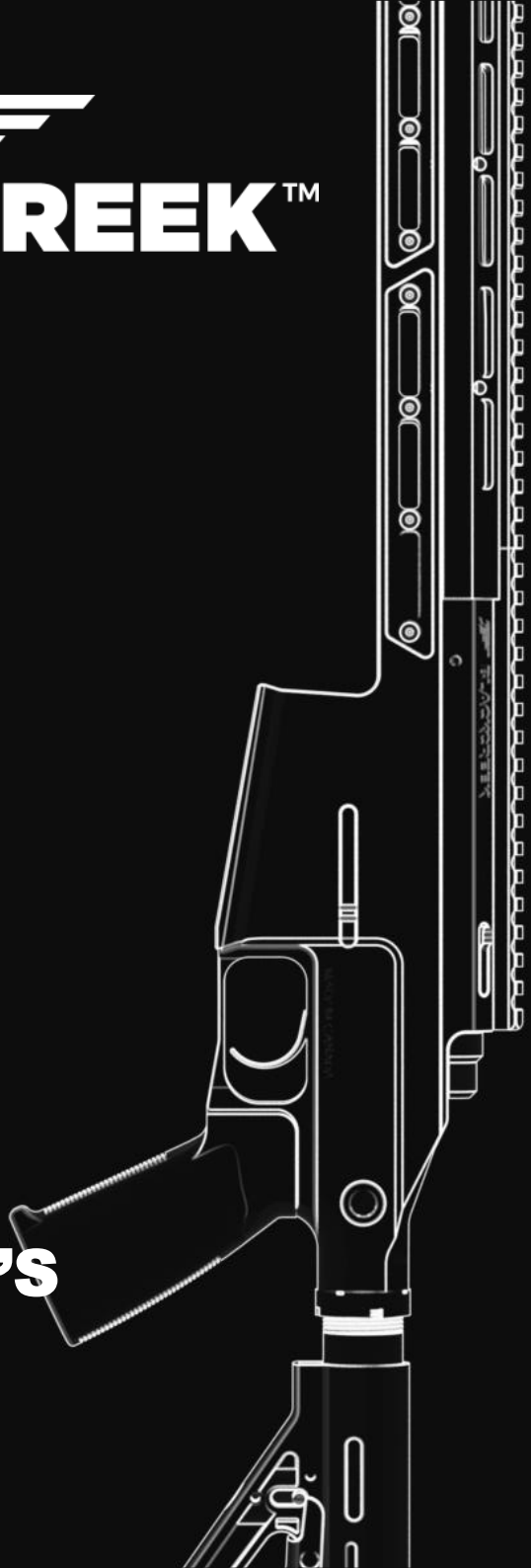

BLACKCREEK™

MRX BISON

**OPERATOR'S
MANUAL**









WARNING

When picking up your firearm for the first time, immediately ensure you prove it is safe. Point the firearm in a safe direction, attempt to put the firearm on safe by pulling the safety selector back into the safe position. Remove the magazine and pull the bolt back into the open position. With the bolt completely to the rear, visually and physically inspect the chamber and feed path to ensure it is empty. Once you have confirmed that there are no rounds or other obstructions in the firearm, push the bolt closed. You have now made your firearm safe to handle.

GENERAL SAFETY

BlackCreek (BCL) has no control over the use of your firearm and shall not be responsible for injury, death, or damage to property resulting from the intentional or accidental discharge of your firearm. Safety is your responsibility and you are required to follow the firearm safety rules at all times:

- Always treat your firearm as though it is loaded.
- Never point your firearm at anything other than the desired target.
- Keep your finger off the trigger until you are ready to shoot.
- Ensure you know what your target is and what lies beyond.

In addition to the firearms safety rules, it is your responsibility to ensure the following:

- Always wear hearing and eye protection when using your firearm.
- Always use your firearm in a well ventilated area to mitigate your exposure to lead and other contaminants.
- Visually inspect your firearm prior to use to ensure there are no obstructions or debris in the barrel, chamber, or action.
- Ensure your firearm is clean and well lubricated prior to use.
- Always carry your rifle in a way that you can control the muzzle in the event of a slip or fall.
- Always use proper, factory-made ammunition of the correct caliber, and ensure it is clean and dry.
- Never shoot directly into hard surfaces, such as rock or water, as bullets can ricochet.
- Do not perform unauthorized modifications or alterations to your firearm.
- Always store your firearm as per the applicable firearms laws and/or regulations.
- Never allow anyone to operate your firearm without reading the operator's manual first.
- Never operate your firearm under the influence of drugs or alcohol.

CONTENTS

GENERAL SAFETY	1
1.0 OVERVIEW	3
1.1 Purpose	
1.2 Chamber	
1.3 Barrel	
1.4 Action	
1.5 Chassis	
1.6 Trigger	
1.7 Barrel Shroud	
1.8 Stock	
1.9 Pistol Grip	
2.0 PHYSICAL DATA	4
3.0 NOMENCLATURE	5
4.0 CARE & CLEANING	7
4.1 Lubricants	
4.2 Field Stripping	
4.3 Further Disassembly	
4.4 Cleaning	
4.5 Lubrication	
4.6 Assembly	
5.0 FUNCTION TEST	18
6.0 SAFETY SELECTOR	18
7.0 FIREARM OPERATION	18
7.1 Proving the Firearm Safe	
7.2 Loading	
7.3 Ready	
7.4 Unloading	
7.5 Immediate Action on Malfunction	
8.0 TROUBLESHOOTING	21
9.0 MAGAZINES	22
10.0 LIMITED LIFETIME WARRANTY	22
11.0 APPENDIX A - SPARE PARTS DIAGRAM	23

1.0 OVERVIEW

The MRX Bison is a compact, rugged bolt action utility rifle that can be chambered in 5.56 NATO, .300AAC, .450 Bushmaster, 7.62x39 and is compatible with AR15 magazines and BCL's proprietary MRX magazines.

1.1 PURPOSE

The MRX Bison is a utility rifle designed to offer a rugged bolt action firearm that can be used for target shooting, hunting or other professional and recreational shooting for distances within 600 yards.

1.2 CHAMBER

The MRX Bison can be chambered in 5.56 NATO, .300AAC, .450 Bushmaster, and 7.62x39. More calibers may become available in the future.

1.3 BARREL

The MRX Bison barrel comes in 12.5" and 16.5" lengths and is made from a button cut, match grade 4140 Chromoly blank. Twist rates are determined by the caliber as described:

5.56 NATO	1:7 Twist
.300AAC	1:8 Twist
7.62x39	1:10 Twist

Barrel life expectancy depends on the number of rounds that have been fired and the rate at which they have been fired at. Firing at controlled rates will allow for minimal accuracy loss starting at 10,000 rounds.

1.4 ACTION

The MRX Bison comes standard with the BlackCreek MRX SuperShort action.

The bolt and receiver are made from high quality AISI 4140 steel and are processed through a proprietary heat treatment process. All parts are machined on cutting edge CNC machinery allowing for top notch precision and endless repeatability.

1.5 CHASSIS

The MRX Bison chassis is machined from 6061– T6 aluminum and finished with a Type III Class 2 hardcoat anodize. The magwell accepts AR style magazines, as well as BCL MRX magazines. The magwell is flared for easy magazine changes. The chassis comes with side and bottom MLOK slots for additional accessories, and an integral QD sling mount on the opposite side of the bolt handle to mount slings for carrying.

1.6 TRIGGER

The MRX Bison comes with a Triggertech Remington 700 field trigger and is designed to work with any Remington 700 compatible trigger.

1.7 BARREL SHROUD

The MRX Bison shroud is 9 inches in length and has an integrated picatinny top rail. It is finished with a Type III Class 2 hard coat anodize. The shroud is available as an aftermarket part.

1.8 STOCK

The MRX Bison comes standard with a Magpul MOE Carbine Stock and a standard carbine buffer tube. Most AR15 stocks are compatible with the MRX Bison.

1.9 PISTOL GRIP

The MRX Bison comes standard with a Magpul MOE K pistol grip. The MRX Bison is compatible with AR15 pistol grips that do not have a beavertail backstrap.

2.0 PHYSICAL DATA

Barrel Length	Action	Overall Length Collapsed	Overall Length Extended	Weight
12.5"	MRX-SS	28.5"	33.3"	6.9lb
14.5"	MRX-SS	30.5"	35.3"	7.1lb
16.5"	MRX-SS	32.5"	37.3"	7.3lb

3.0 NOMENCLATURE

The following drawings and associated parts list provide a visual reference to the parts of the MRX Bison described in the manual.

1. Carbine Stock

2. Safety Selector
(Shown as Safe)

3. Bolt Handle

4. Bolt Shroud

5. Muzzle Jam

6. Muzzle Device

7. Magazine Release Button

8. QD Sling Point

9. Pistol Grip

10. Trigger

11. Bolt Catch Release

12. Barrel

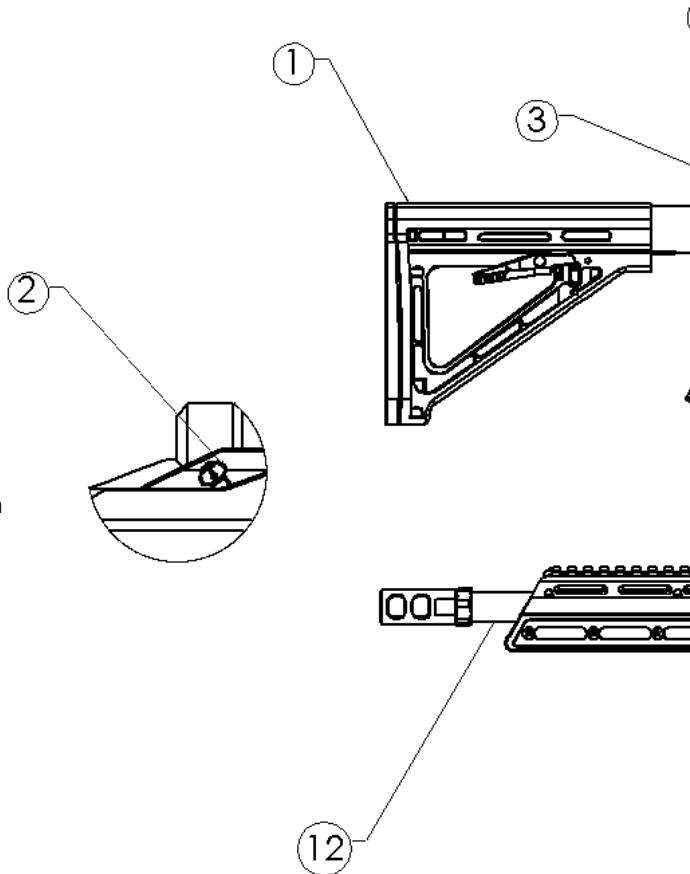

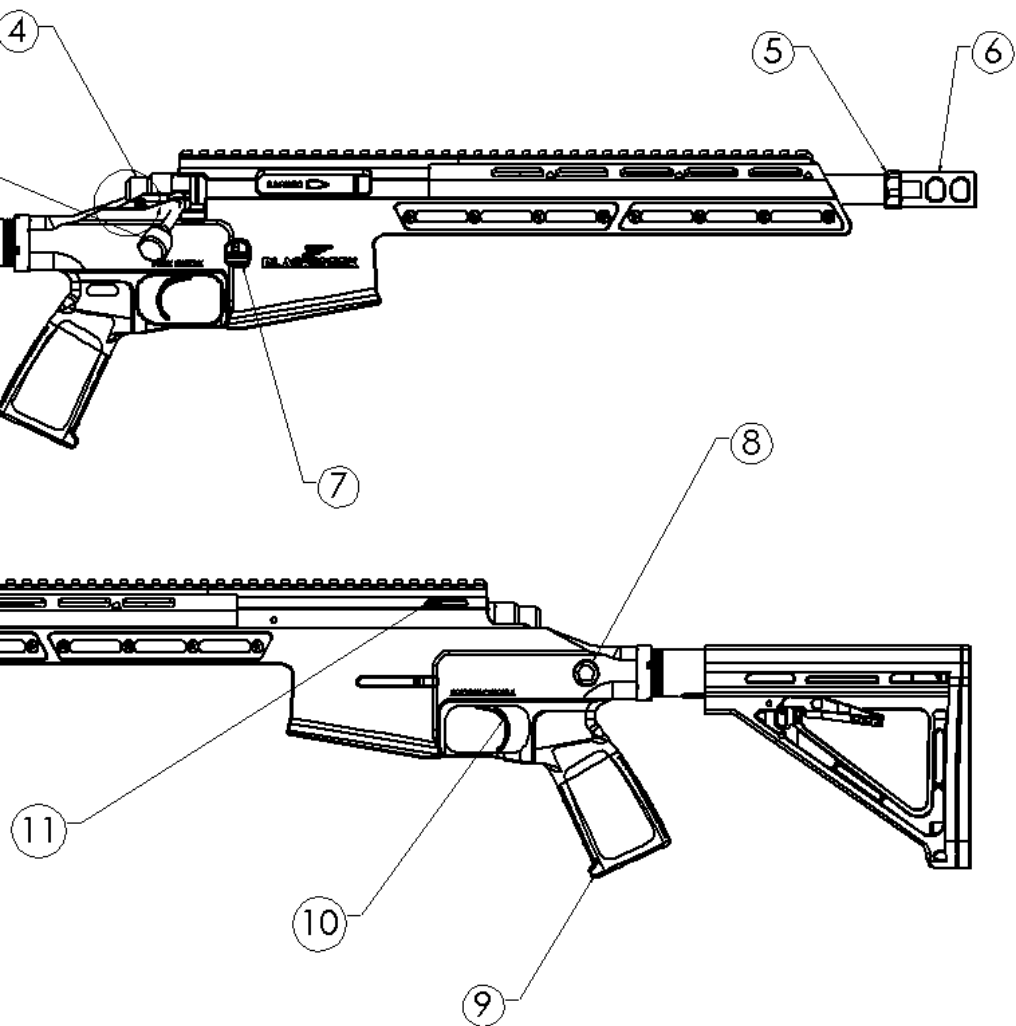

4.0 CARE & CLEANING

Your firearm should be cleaned before and after every use. Regular cleaning is important for your firearm to operate correctly. Cleaning your firearm requires it to be field stripped so you can remove carbon, fouling, dust and debris, and add lubrication.

Additional care and cleaning are required when operating the firearm in:

DUSTY AND SANDY AREAS

- Clean the firearm before and after firing and/or at least once per day.
- Reduce excess lubrication to avoid dust, dirt, or sand sticking to the lubrication and causing additional friction and wear in the moving parts.
- Keep the firearm covered whenever possible.

TROPICAL CONDITIONS (HOT AND HUMID)

- Clean the firearm before and after firing and/or at least once per day.
- Keep steel parts well oiled, and inspect for rust at least once per day.
- After handling, wipe the firearm down with an oiled cloth to remove precipitates, which will accelerate corrosion.

ARCTIC CONDITIONS

- Clean the firearm before and after firing and lubricate sparingly
- Cycle the firearm frequently to prevent the mechanism from freezing

4.1 LUBRICANTS

Any number of lubricating and/or off the shelf gun cleaning oils, greases, or solvents can be used on the MRX Bison. BlackCreek recommends a CLP for mechanical components, which cleans, lubricates, and protects your firearm.

4.2 FIELD STRIPPING

In order to properly clean your firearm, it must be field stripped. "Field stripped" is the term for when the bolt is removed from the action for cleaning. This is the minimum level of disassembly required to properly clean your firearm.

ALWAYS BEGIN A FIELD STRIP BY PROVING THE FIREARM SAFE AND ENGAGING THE SAFETY. ALWAYS WEAR EYE PROTECTION AND GLOVES WHEN FIELD STRIPPING YOUR FIREARM.

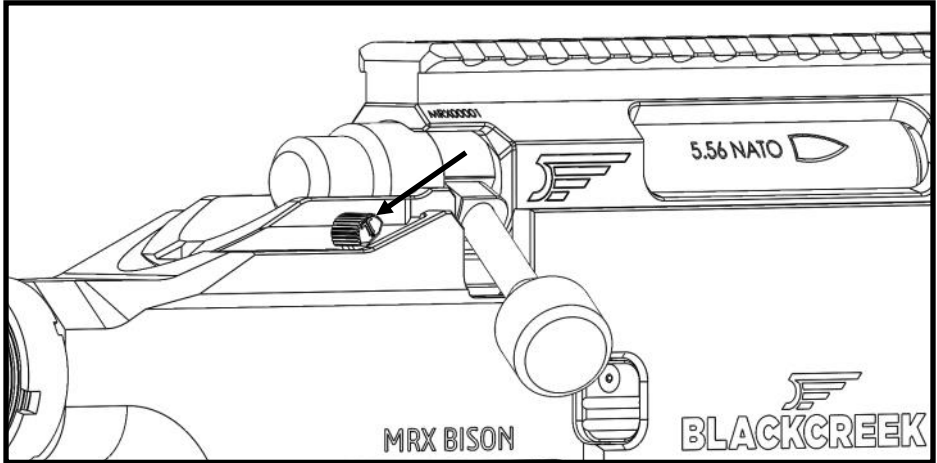

1. Pull safety selector back into “safe” position.

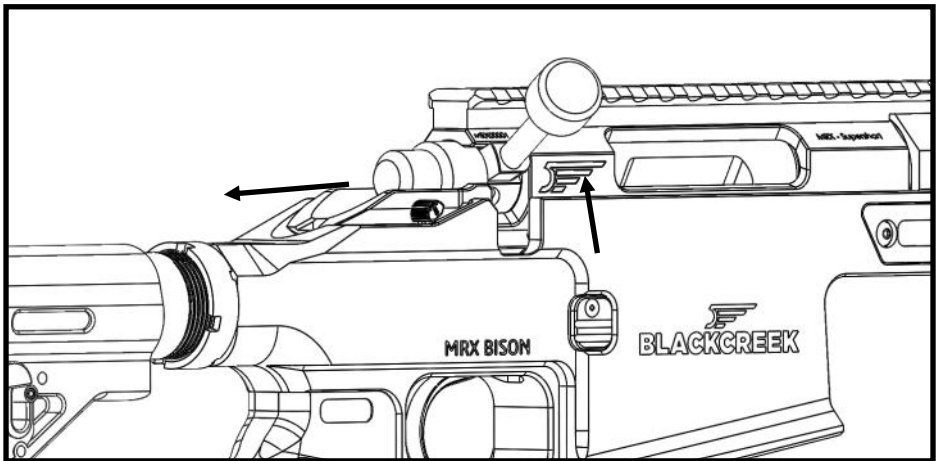

2. Rotate the bolt handle upwards as far as it can go. Then withdraw the bolt from the action until you feel it hit the bolt catch.

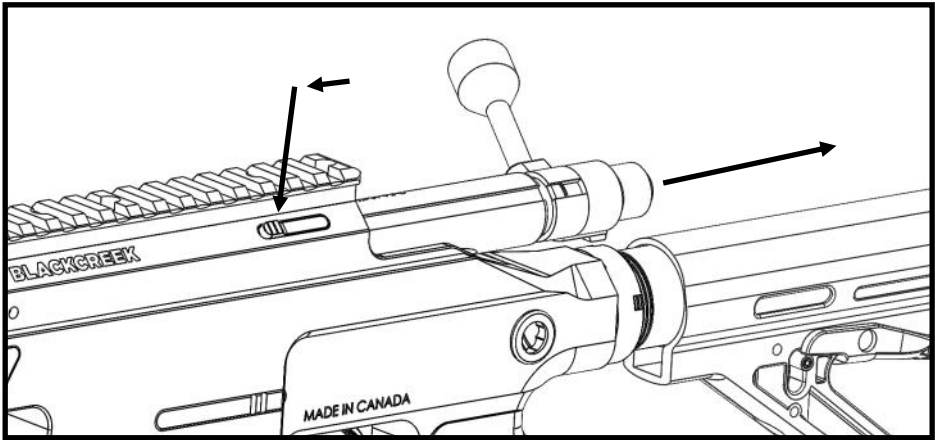

3. Slide the bolt action release forwards and then push down on the raised button. Then, carefully remove the bolt by drawing it backwards and out.

If you have a cheek riser you may need to extend your stock out of the way before bolt removal.

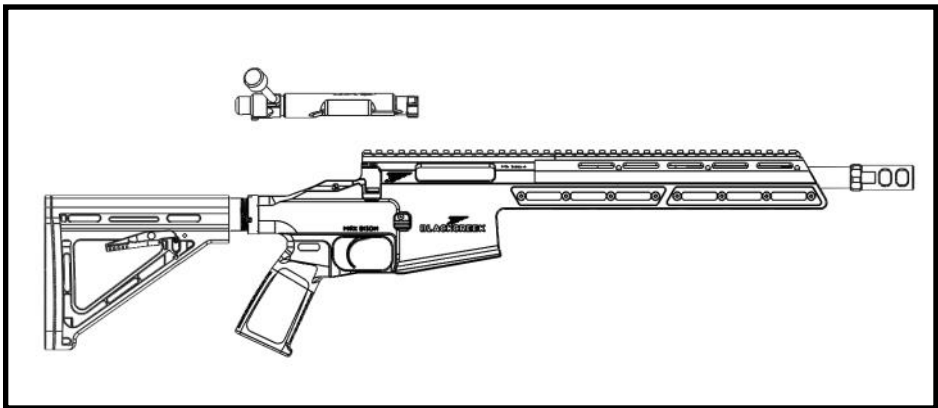

4. Bolt fully removed from the firearm.

The firearm is now field stripped and ready for routine cleaning.

4.2 Further Disassembly

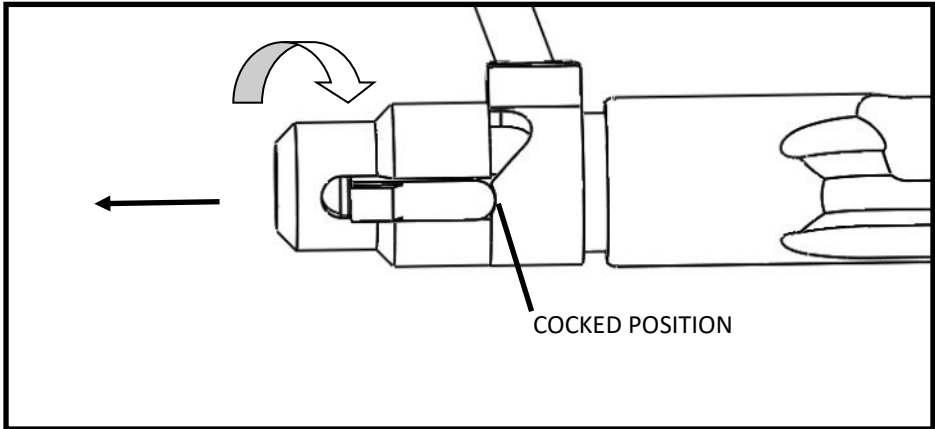

5. To access the firing pin, the bolt shroud must be twisted clockwise from its cocked position (Away from the cocking ramp). The bolt shroud can then be pulled outwards. The shroud is under spring tension and will want to spring out, be careful not to lose any components.

IF THE FIRING PIN IS AT THE BOTTOM OF THE COCKING RAMP, IT WILL HAVE TO BE MOVED UP TO COCKED POSITION BEFORE THE BOLT SHROUD CAN BE REMOVED

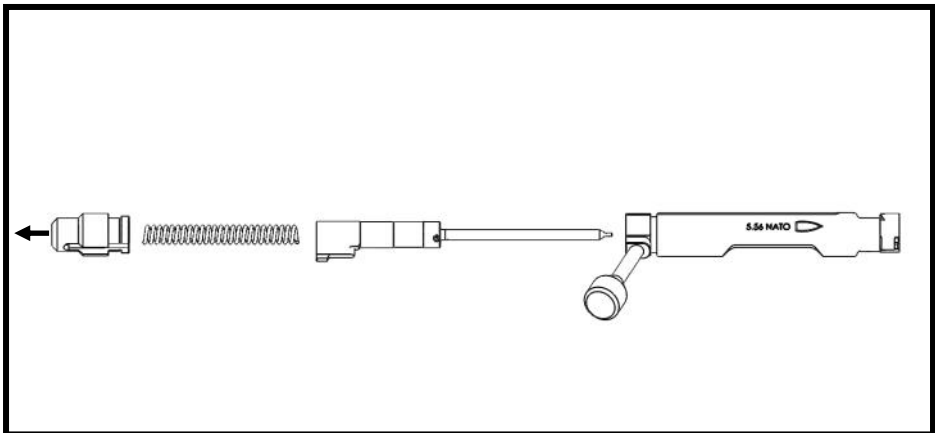

6. The firing pin and sear can be removed from inside the bolt.

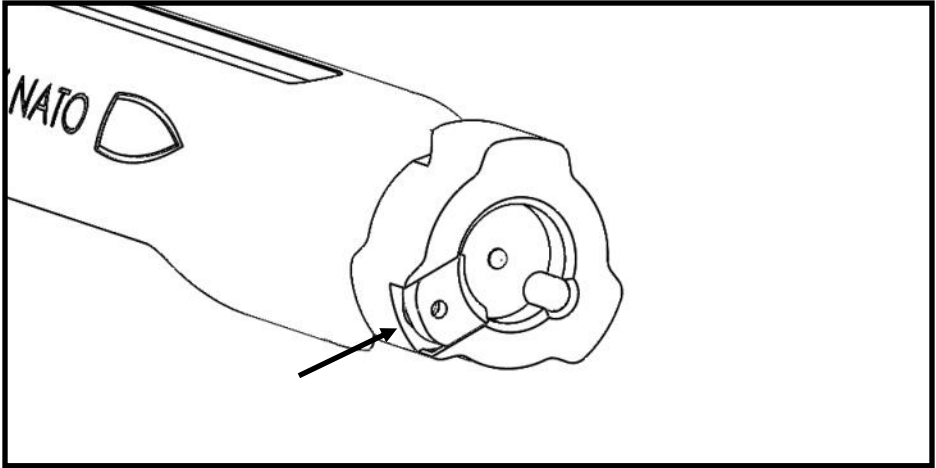

7. OPTIONAL: The extractor can be removed by pressing it towards the centre of the bolt. Handle with extreme care as the small detent beneath is spring loaded and can be lost easily. Do not remove the extractor in the field unless absolutely necessary. A clean, level, work surface is recommended when disassembling.

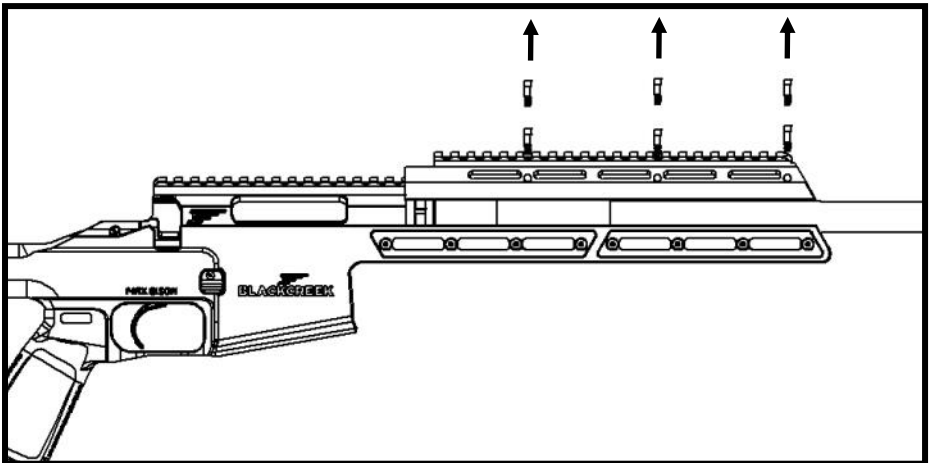

8. If the rifle has an optional barrel shroud installed, it must be removed prior to the installation or removal of the action using a 7/64" Allen Key. The shroud can be taken off by loosening and removing the six shroud screws. The recommended torque value is 20 in-lb for reassembly.

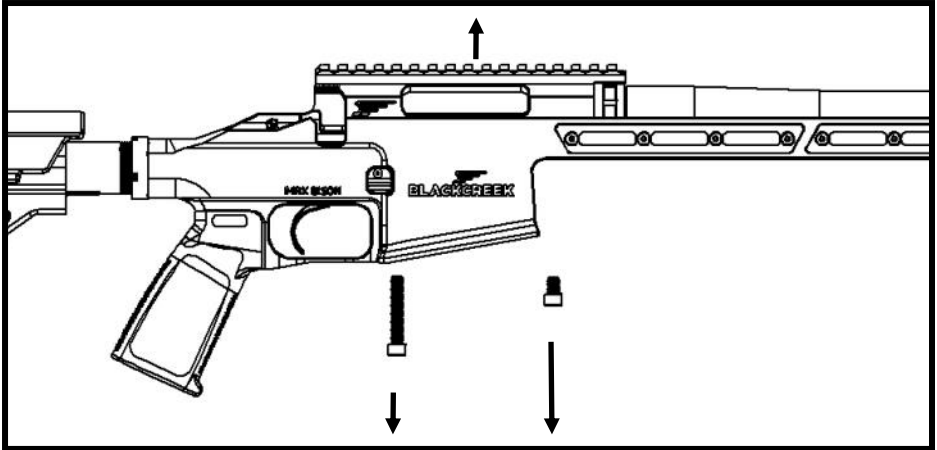

9. The action can be removed by removing the actions screws from beneath the chassis using a 3/16" Allen Key. The recommended torque value is 60in-lb for reassembly.

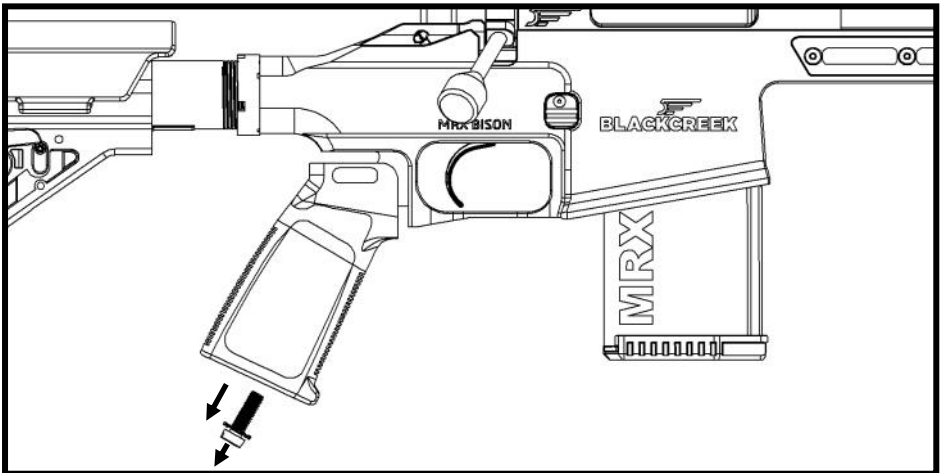

10. The grip can be removed by unscrewing the bolt using a 3/16" Allen key from below the grip.

4.4 CLEANING

Once your firearm is field stripped, you can begin to clean:

1. Spray CLP or a firearm cleaning solvent on the bore, chamber, barrel, locking lugs, and all other areas where carbon, fouling, corrosion, or dirt is visible or could potentially build up. Let the solvent sit for 5 minutes or as per the manufacturer's instructions.
2. Use a bore brush to break up carbon in the bore.
3. Use a cleaning rod with a cleaning patch and run it through the barrel until all fouling is removed and the patch runs through the barrel clean.
4. Use a patch to remove all fouling and excess oil from the chamber, and locking lugs.
5. Remove all carbon and brass deposits from the bolt face and lugs.
6. Clean the extractor groove and remove all brass shavings.
7. Check the extractor for wear and spring tension. Replace if necessary.
8. Clean carbon and debris from bolt surface.
9. Wipe down bolt shroud, firing pin spring and firing pin.

4.5 LUBRICATION

Use CLP or a lubricating oil/grease for firearms to lubricate your firearm after cleaning. Do not use lubricants containing graphite as graphite can cause damage to aluminum alloys.

1. Lightly grease riding surfaces of the firing pin and firing pin spring.
2. Lightly grease the bore of the receiver to prevent excessive wear on the bolt.
3. The trigger sear, bolt face and chamber should be cleaned, but any oil or grease should be wiped off immediately.

4.6 ASSEMBLY

After cleaning and lubrication, the rifle is ready to reassemble.

ALWAYS BEGIN ASSEMBLY BY PROVING THE FIREARM SAFE. ALWAYS WEAR EYE PROTECTION AND GLOVES WHEN ASSEMBLING YOUR FIREARM.

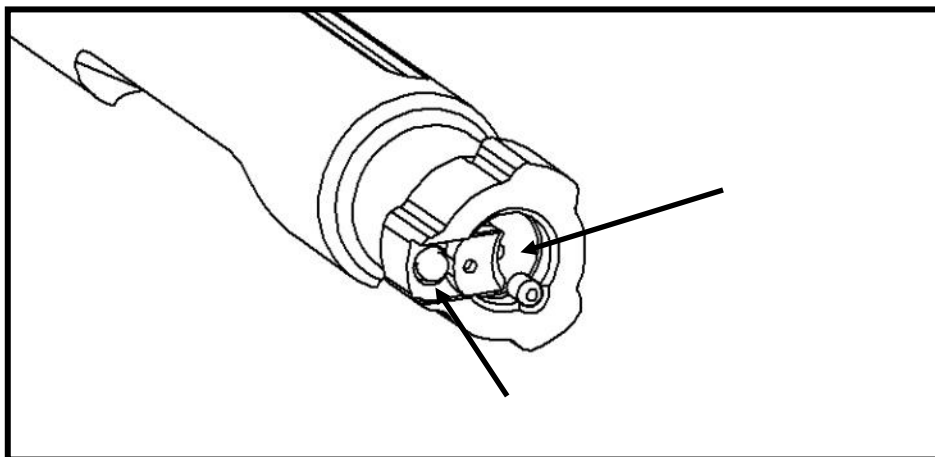

1. The extractor can be assembled by replacing the extractor spring and inserting the detent above it. Press the detent down with a flat head screwdriver and slide the extractor outward and into position.

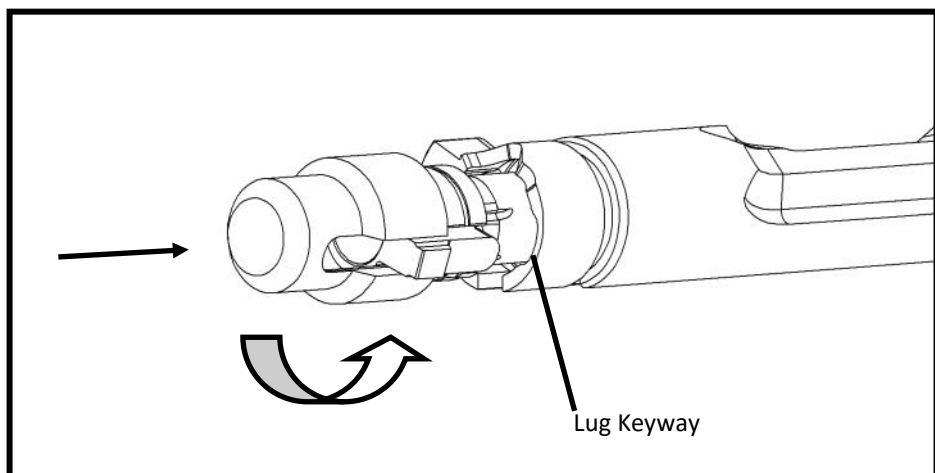

2. The firing pin can be slid back into the bolt and the firing pin spring inserted behind. The bolt shroud should be placed over top making sure to line its lugs up with the corresponding keyway in the bolt. Also ensure the firing pin sear is in the slot of the bolt shroud. The shroud can then be inserted until it rests against the bolt and turned counter clockwise into its cocked position to secure it.

MAKE SURE NOT TO TURN THE SHROUD TOO FAR AND SEND THE FIRING PIN DOWN THE COCKING RAMP

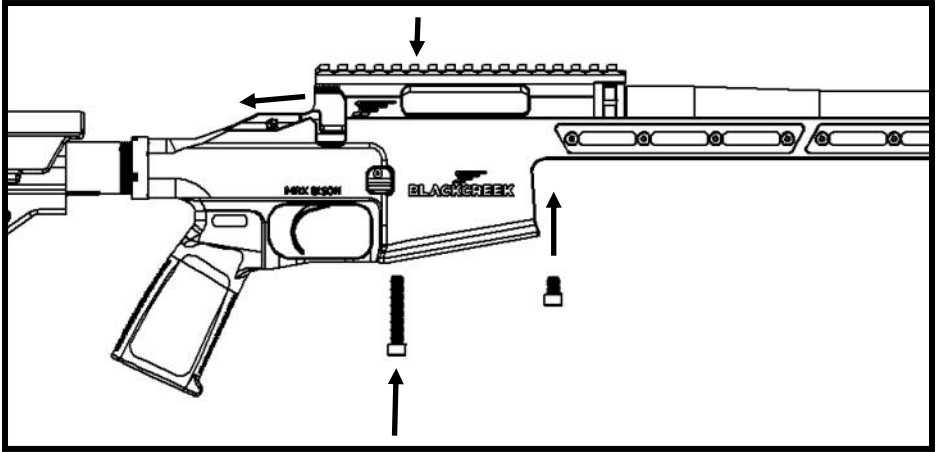

3. When putting the action back on the chassis, pull the action rearward firmly as you alternate torquing the action screws using a 3/16" Allen Key in 10in-lb increments to 60in-lb total each.

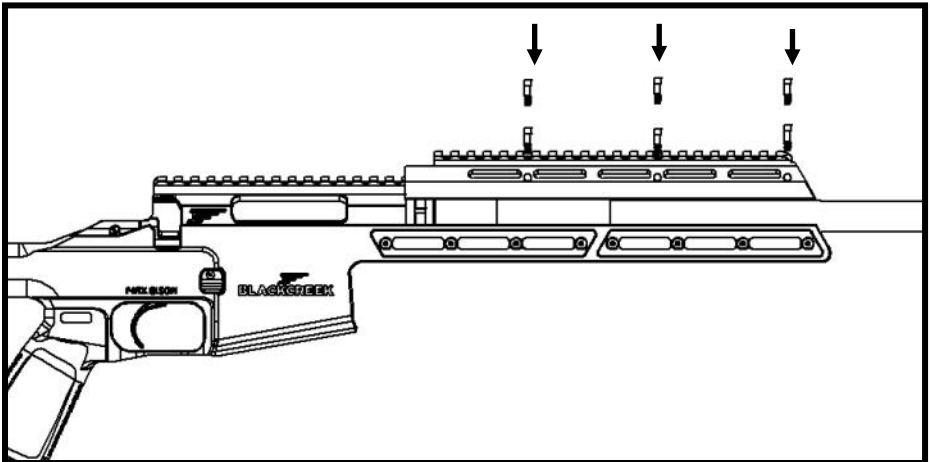

4. Reattach the shroud using a 7/64" Allen Key. Tighten in 10 in-lb increments, alternating bolts to 20 in-lb each.

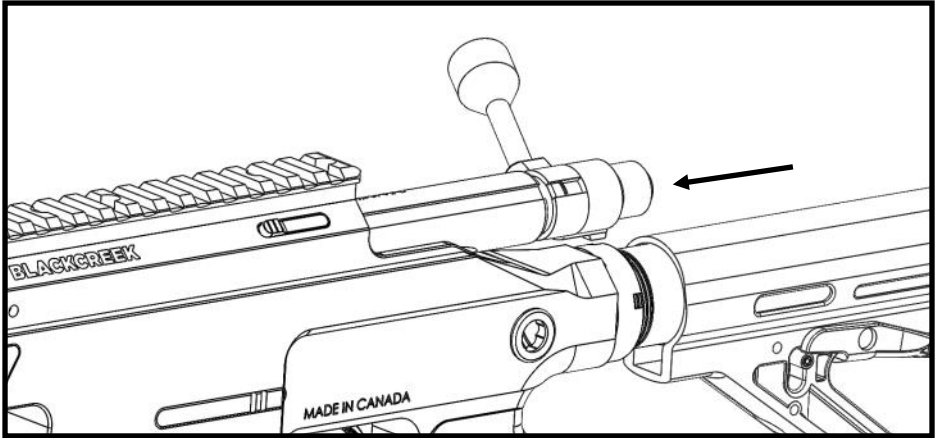

5. Line up the slot in the bolt with the action and insert to finish assembly.

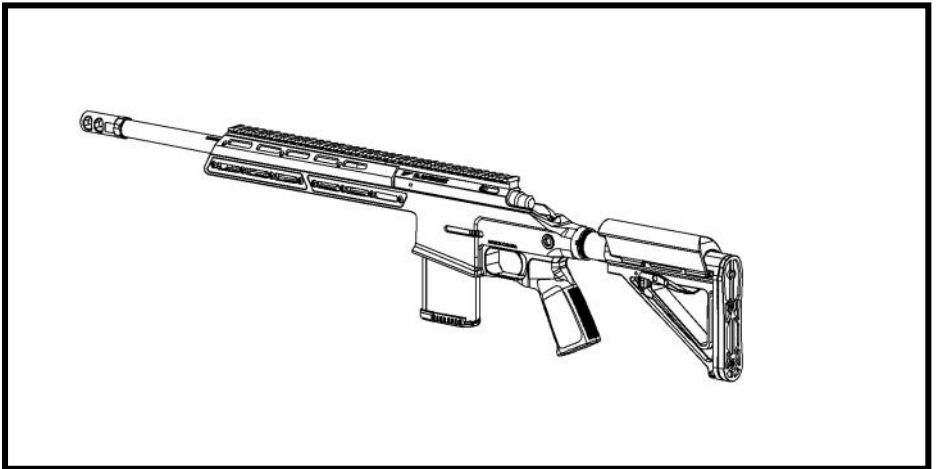

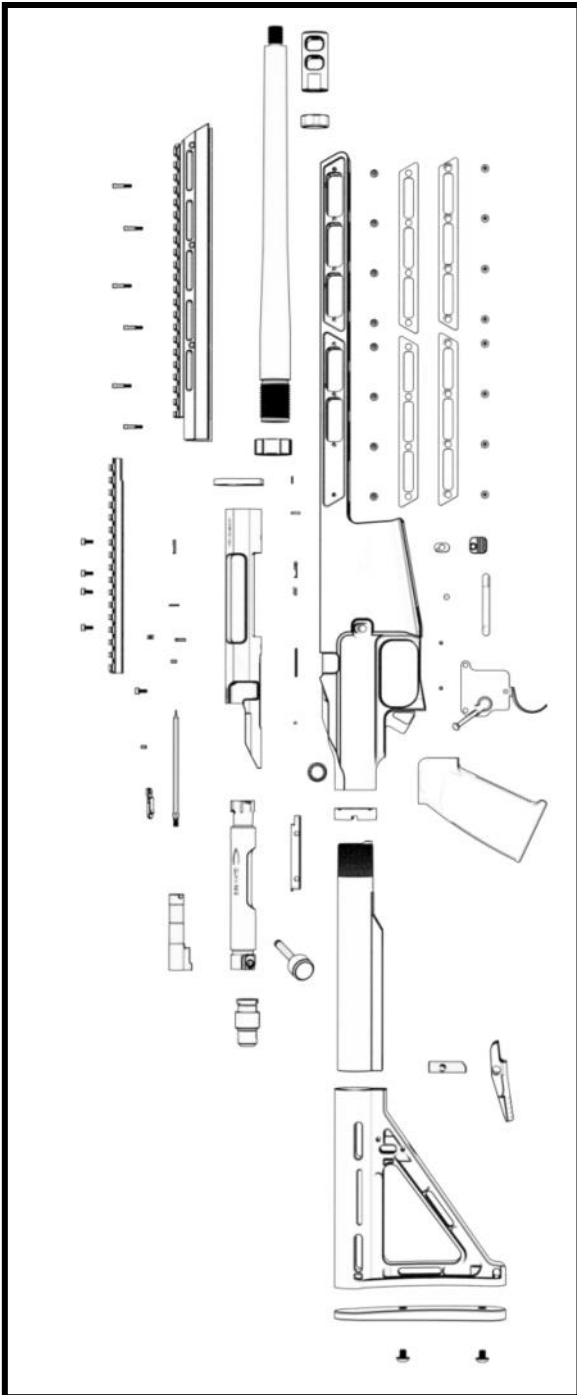

5.0 FUNCTION TEST

Test the function of the firearm after assembly, with the magazine removed, as follows:

- **PROVE THE FIREARM SAFE PRIOR TO FUNCTION TEST.**
- Lock the bolt, move the safety selector rearward to safe , and squeeze the trigger. The firing pin should not be released.
- Move the safety selector forward to “fire” and squeeze the trigger. The firing pin should release.
- Cycle the action fully and repeat.

6.0 SAFETY SELECTOR

When the safety is sitting in the rearward position (safe position), the firearm should not fire. Always attempt to place the firearm safety into “safe” when loading, unloading, or handling.

7.0 FIREARM OPERATION

The operation of this firearm should only be performed by persons who are trained to do so. The operational instructions in this manual are a guide for safe use but are not meant to replace the requirement of formal training.

7.1 PROVING THE FIREARM SAFE

Making or proving the firearm “safe” is a technique that ensures there are no rounds or other obstructions in the chamber or magazine of the firearm so it can be handled and/or transported safely. To prove the firearm safe, follow these steps:

1. Assume the firearm is always loaded and maintain safe muzzle control.
2. Engage the safety if possible.
3. Keep your finger off the trigger.
4. Remove the magazine.
5. Unlock the bolt and pull rearward.
6. Visually and physically check to ensure that the chamber and feed path are clear of any ammunition.

7.2 LOADING

Loading is a term that is used to describe when the magazine is inserted into the magazine well of the rifle. To load the firearm, follow these steps:

1. Prove the firearm is safe as per section 7.1.
2. With the firearm pointed in a safe direction, push the magazine (bullets facing forward), into the magazine well until the magazine catch engages with a positive click.
3. Pull down on the magazine to ensure it is locked in place properly.

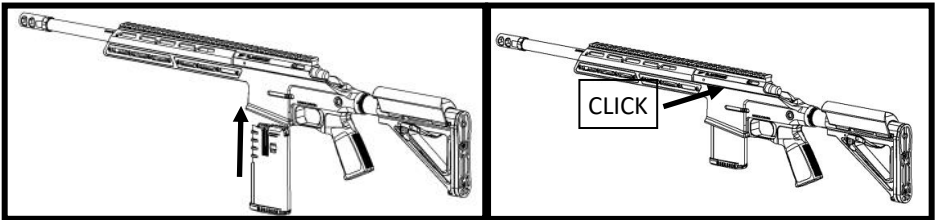

Loading a magazine.

WARNING—AMMUNITION NOTICE

Some brands of ammunition are designed for semi-automatic use only. Ammunition labelled as “AR” ammunition, as well as some other brands may cause failure to fire (light strikes) due to primers that can only be ignited with a semi-automatic trigger group or a much heavier firing pin spring. It is recommended that non “AR” marketed ammunition is to be used in the MRX Bison.

Only load your firearm with clean, high quality, factory made ammunition. Do not load ammunition that is dirty, wet, corroded or damaged. The MRX Bison is designed and tested using most commercially available ammunition. Should you encounter issues with an ammunition, try another brand and contact BCL directly.

Black Creek Laboratories specifically dismisses any responsibility for any damage or injury caused in connection with, or as a result of, the use of any non-factory ammunition. Any damage caused by non-factory-made ammunition voids all warranties. Reloading ammunition is a strict science that can be extremely dangerous if done improperly. Only use ammunition that complies with SAAMI or similar specifications, unless otherwise directed by Black Creek Laboratories (such as for international exports).

7.3 READY

Ready or “making ready” is the term used to describe when a round is chambered. To make ready, follow these steps:

1. Ensure the magazine is seated properly.
2. If the bolt is not already all the way at the rear, pull the bolt all the way towards the rear.
3. Push the bolt forward completely in a smooth, firm motion.
4. Lock the bolt fully by rotating the bolt handle down as far as it goes.
5. Place the rifle on safe .

7.4 UNLOADING

1. Attempt to place the safety selector on safe.
2. Press the magazine catch button and remove the magazine.
3. Pull the bolt handle to the rear.
4. Check to ensure the action and chamber is clear. Observe the feeding path.
5. Push bolt forward and lock into place.
6. Keep the safety selector on safe.

7.5 IMMEDIATE ACTION ON MALFUNCTION

A malfunction is a failure of the firearm to function correctly. Malfunctions are caused by procedural or mechanical failures of the firearm, magazine, operator, or ammunition. Proper care, cleaning, and maintenance can mitigate mechanical malfunctions and identify problems before they occur. If a firearm fails to fire, the immediate action is: **Stop shooting and keep rifle pointed at target for 60 seconds in case of hang fire.**

After you wait 60 seconds inspect your firearm. Check to see if you have unusual chambering, misfire, failure to extract, unburned powder residue, abnormal sounding and/or unusual feeling shot. Sometimes improper ammunition and/or chambering leads to a projectile not exiting the barrel after firing. Firing a round into a blocked barrel is extremely dangerous and can cause serious injury and/or death.

Initial corrective action:

- Pull bolt back.
- Check to ensure the previous cartridge was extracted properly.
- Check to ensure a new cartridge was pushed into the chamber.
- Check the magazine to ensure that it is fully seated and locked in place while firing.
- Examine the action and chamber of the firearm for any signs of failure.

- If a live round or empty casing is in the receiver or chamber, remove the magazine.
- Clear the obstruction.
- Check to see if the magazine is empty.
- Change the magazine.
- Re-aim and continue firing.
- If the firearm fails to fire, take further corrective action.

8.0 TROUBLESHOOTING

PROBLEM	COMMON CAUSE	CORRECTIVE ACTION
Failure to Fire	Safety selector is on Safe Improper assembly of the firing pin/ damaged firing pin Excessive oil in the firing pin hole Hard cartridge primer Excessive carbon fouling on bolt face and firing pin	Move safety selector to Fire Ensure assembly is correct Clean bolt face thoroughly Remove any carbon fouling Check ammunition Try another type of cartridge
Bolt Won't Unlock from Chamber	Dirty bolt Burned bolt Improper ammunition	Clean bolt and chamber Ensure ammunition is correct Contact BCL directly for assistance
Failure to Extract	Broken extractor or spring Dirty bolt or chamber Dirty or corroded ammunition	Remove bolt and extractor and check for any wear Clean chamber and bolt Replace extractor spring
Failure to Feed	Dirty or corroded ammunition Defective magazine Magazine not loaded correctly Feed speed too slow (AR mag)	Clean or replace magazine Firmly press the magazine up into the magwell Ensure you do not chamber round too slowly (AR Magazines)
Failure to Eject	Broken Ejector Spring Broken Extractor	Remove bolt ensure all parts are correctly assembled Clean bolt face and chamber

9.0 MAGAZINES

Your firearm may come with a plastic or steel magazine. The MRX Bison is designed to be used with BCL's proprietary magazine or any AR15 pattern magazine.

NOTE: AR15 magazine feed lips are designed to run effectively in AR15 rifles. To ensure proper feeding and extraction in the MRX Bison, the action must be cycled in a smooth, distinct motion.

10.0 LIMITED LIFETIME WARRANTY

BlackCreek warrants to the original retail purchaser of a new firearm from BlackCreek that such firearm shall be free from defects in material, workmanship, and mechanical function. Repair or replacement of the firearm is at the discretion of Black Creek Laboratories. The Purchaser's remedies under this warranty are limited to repair or replacement of the firearm; firearm must be registered, and a valid warranty claim must be submitted. Black Creek Laboratories will not provide cash, credit, or refund. If Black Creek Laboratories opts to replace the firearm, Black Creek Laboratories will keep the firearm that it replaces. Black Creek Laboratories does not warrant against any type of defect to the firearm that Black Creek Laboratories did not cause, including but not limited to damage or defects arising out of:

- Improper maintenance and care,
- Accidents, abuse, or misuse,
- Normal wear; tear; and/or corrosion,
- Barrel obstruction,
- Unauthorized adjustments, repairs, or modifications,
- Improper ammunition

11.0 SPARE PARTS DIAGRAM

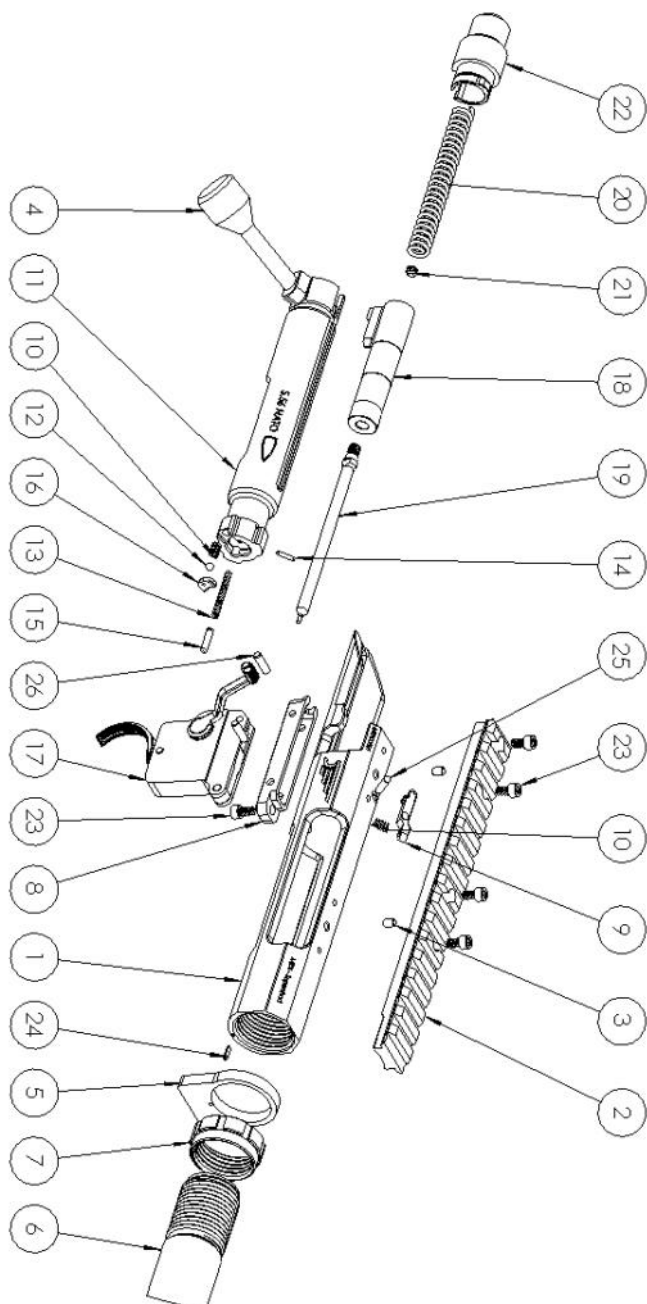

ITEM NO.	DESCRIPTION	QTY.
1	RECEIVER	1
2	PICATINNY SEGMENT	1
3	PICATINNY DOWEL PIN	2
4	BOLT HANDLE	1
5	RECOIL LUG	1
6	BARREL	1
7	BARREL NUT	1
8	TRIGGER HANGER	1
9	BOLT CATCH	1
10	EXTRACTOR/BOLT CATCH SPRING	2
11	BOLT	1
12	EXTRACTOR DETENT	1
13	EJECTOR SPRING	1
14	EJECTOR CROSS PIN	1
15	EJECTOR	1
16	EXTRACTOR	1
17	TRIGGERTECH	1
18	FIRING PIN SEAR	1
19	FIRING PIN	1
20	FIRING PIN SPRING	1
21	FIRING PIN JAM SCREW	1
22	FIRING PIN ENDCAP	1
23	PICATINNY/TRIGGER HANGER SCREW	5
24	RECOIL LUG ALIGNMENT PIN	1
25	BOLT CATCH PIN	1
26	TRIGGER PIN	2

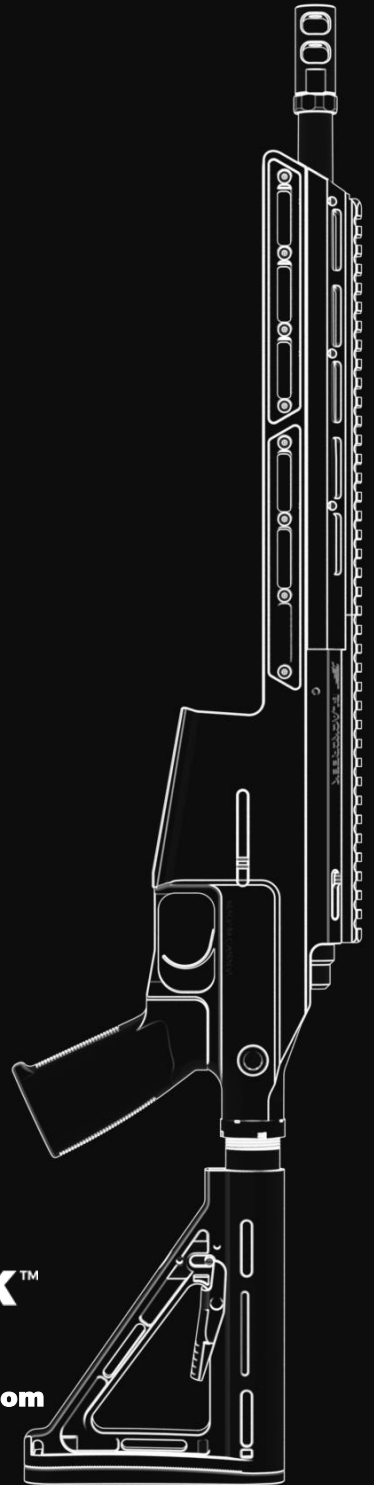

BLACKCREEK™

Ontario, Canada
www.blackcreeklabs.com