



Mauser 98 Scope Mount

Installation Instructions

PART# MSM1700

Advanced Technology
INTERNATIONAL

Thank you for purchasing an ATI product!



Stock Installation

Point the rifle in a safe direction and place the safety in the "on" position. Next remove the magazine, pull back and carefully inspect the chamber to be sure the rifle is unloaded.



IMPORTANT: This product may require installation of ATI's Mauser 98 Bolt Handle (sold separately, part#MBH1800) in order to prevent the bolt from hitting your scope. See above model.

Step #1

Remove barreled action and trigger guard/magazine from the stock.

Step #2

Refer to figure #1, remove the wood in the area shown to create a relief for the barrel/scope rail clamp. (1-1/4" WIDE x 1-3/4" LONG x 1-1/6" DEEP)

Note: Measure carefully to prevent puncturing the stock while removing material. Use included clamps as a guide.

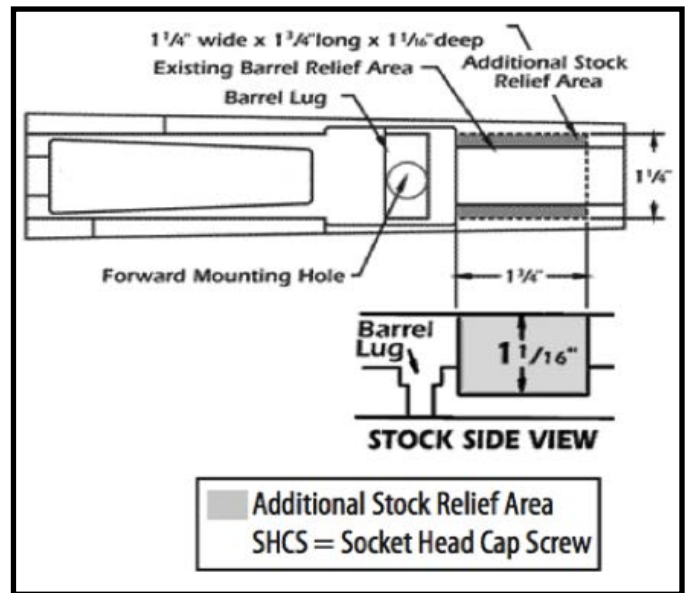

Figure 1

Advanced Technology International • Made In the USA • Limited Lifetime Warranty

2733 West Carmen Ave • Milwaukee, WI 53209

Toll Free: 800.925.2522 • Fax: 414.464.3112

www.ATIGunstocks.com



Mauser 98 Scope Mount

Installation Instructions

PART# MSM1700

Advanced Technology
INTERNATIONAL

Thank you for purchasing an ATI product!



Stock Installation

Point the shotgun in a safe direction and place the safety in the "on" position. Next pull back the slide, and carefully inspect the chamber and magazine to be sure the shotgun is unloaded.

Step #3

Refer to figure #2, place clamps on the barrel between the receiver and the rear sight as shown with circular relief towards the receiver. Tighten the (2) #10-32 x 1/2" SHC screws into the counterbored holes at the top. Now place the (2) #10-32 x 3/4" SHC screws in the bottom holes, but do not tighten. Place the scope rail over the clamp and tighten the (4) #8-32 x 1/2" SHC screws as shown in figure #2.

Note: On some Mausers it may be necessary to remove the rear sight. Move the scope rail and clamp forward or back for proper alignment. Make sure that the scope rail does not interfere with the bolt.

Step #4

Place the action back into the modified stock and check for fit and alignment. Once proper alignment has been achieved, remove the barreled action from the stock and tighten the (2) bottom #10-32 x 3/4" SHC screws. Now reassemble the Mauser, place the #10-32 x 3/4" set screw in the rear hole until snug. You are now ready to install scope and rings

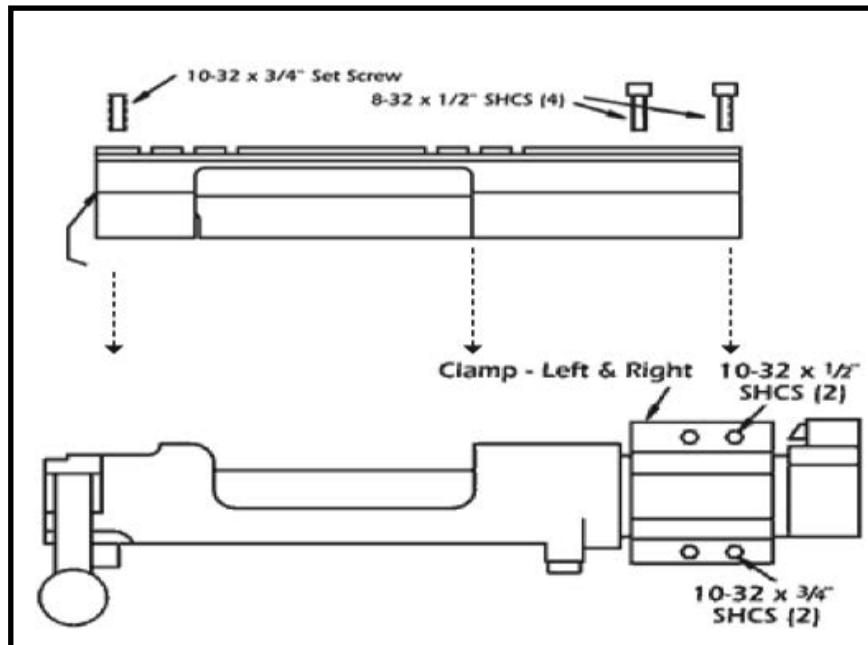

Figure 2

Advanced Technology International • Made In the USA • Limited Lifetime Warranty

2733 West Carmen Ave • Milwaukee, WI 53209

Toll Free: 800.925.2522 • Fax: 414.464.3112